

X10 mini wing servo

Technical Specification

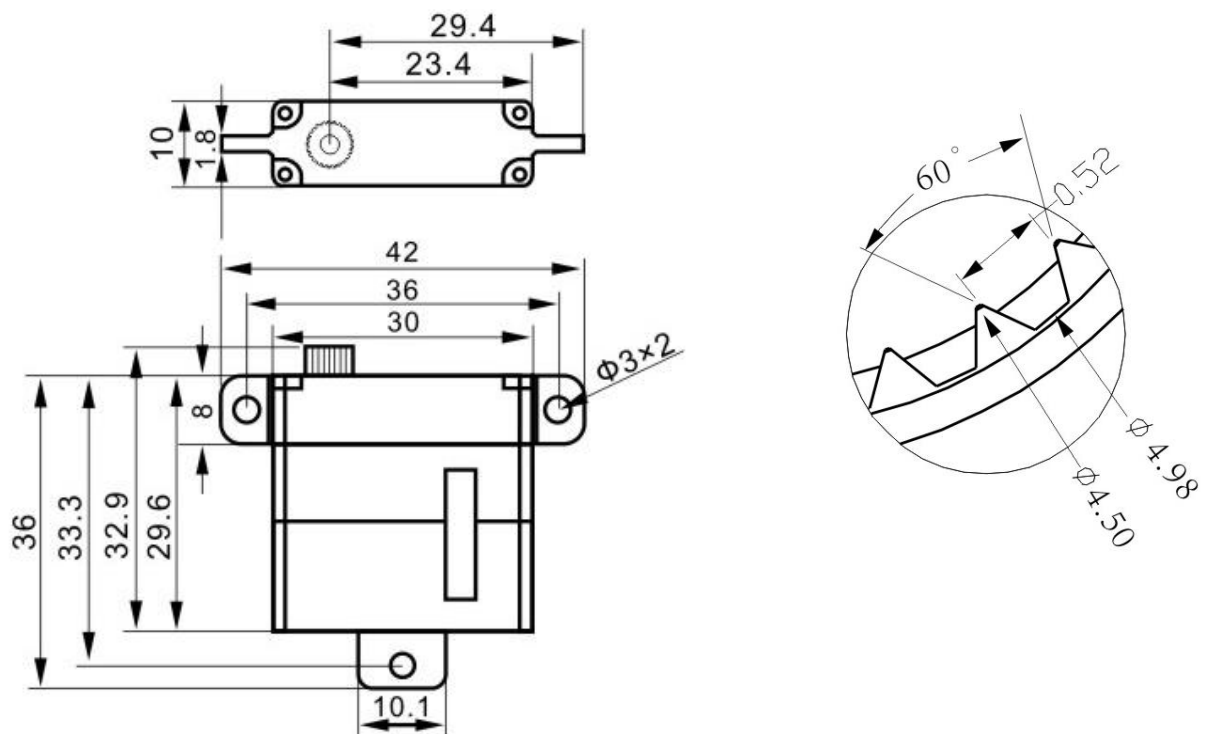

Operating Data

	X10 mini
Operation Voltage(rated)	DC7.4V
Operation Voltage Range	DC4.8V-8.4V
Torque	4.5Kg.cm@4.8V
	5.5Kg.cm@6.0V
	6.8Kg.cm@7.4V
	7.50Kg.cm@8.4V
Speed	0.16sec/60 °@4.8V
	0.14sec/60 °@6.0V
	0.12sec/60 °@7.4V
	0.10sec/60 °@8.4V
Travel Angle	± 50° when 1000-2000us
Operating Temperature Range	-20°C ……+65°C

Performance

X10 mini

@7.4V

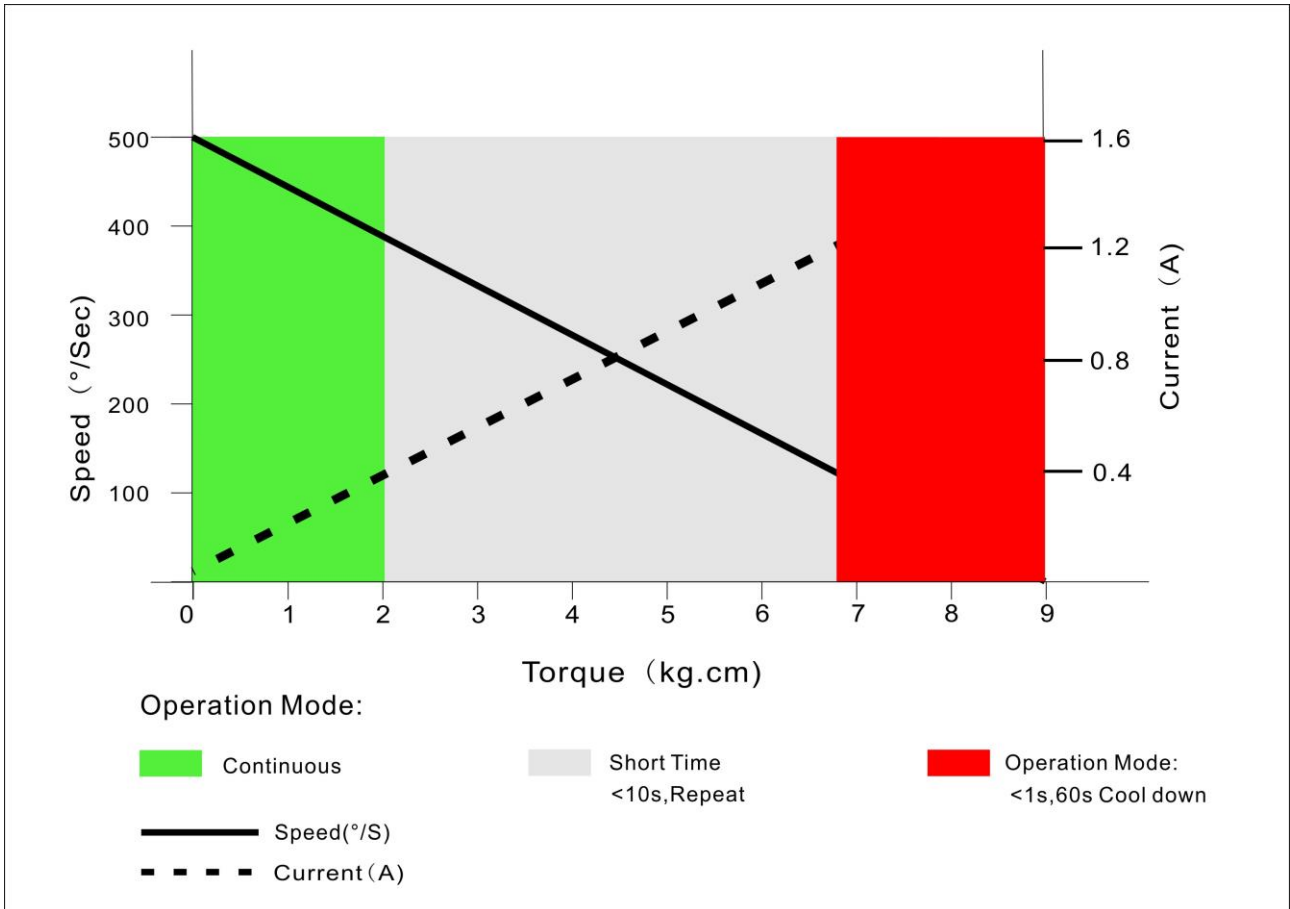



PWM Command Signal

PWM	X10 mini
Signal Voltage	TTL-Level: HIGH:min.3.3V,max.5.0V TTL-Level: Low:min.0.0V,max.1.5V
Pulse Lengths	900-2100us
Pulse Lengths for Position -50° /center/+50°	1000us/1500us/2000us
Resolution	<2us

Materials and protective features

Case Material	Aluminum Alloy
Salt Water Resistance	
EMI/RFI Shielding	Shielding
Motor Type	Coreless
Gear Set Material	Hardened Steel
Position Sensor	Potentionmeter
Position Feedback	Optional
Shielded Connecting Cable	26AWG

Dimensions

Case Dimensions	30*10*30mm
Weight	23g